

Standard Preparation 1200 mm Ventilated Hot Cupboard with Shelf & Sliding Doors - no top

ITEM # _____

MODEL # _____

NAME # _____

SIS # _____

AIA # _____

133189 (RHC1200SD)

Hot Cupboard with sliding doors - no Top, 1200mm

Short Form Specification

Item No. _____

Made entirely from stainless steel. Inner welded frame in stainless steel. No top unit for integrated solutions. Sound-deadened sliding doors. Base panel in 304 AISI stainless steel and height adjustable intermediate shelf. Mounted on feet, adjustable in height. Ventilated hot air flow system guarantees temperature evenness, air flows underneath the intermediate shelf and throughout the cabinet. Thermostat with digital display to adjust the internal temperature (up to 75°C).

Main Features

- Ideal for central positioning in the kitchen, either as island installation or back to back.
- Handles in stainless steel for better hygiene and reliability.
- Sturdiness, stability and reliability of table accurately tested.

Construction

- Reinforced side and base panel in 304 AISI stainless steel.
- 304 AISI stainless steel feet, 200 mm high and 54 mm in diameter, adjustable by -50/+30 mm.
- Inner welded frame in stainless steel to guarantee superior strength and stability.
- Equipped with intermediate shelf which can be positioned at three different heights.
- Sturdy sound-deadened sliding doors on tracks located flush to the front of the frame.
- Easy access to the cupboard interior on all lengths guaranteed by the use of only 2 doors.
- Without top for integrated solutions.
- 100 mm upstand with 10 mm radiused corner and 13 mm deep, designed to be used against a wall.

Optional Accessories

- Stainless steel front kicking strip PNC 133205
- Side kicking strip, 700 mm PNC 133206

APPROVAL: _____

Standard Preparation 1200 mm Ventilated Hot Cupboard with Shelf & Sliding Doors - no top

Front

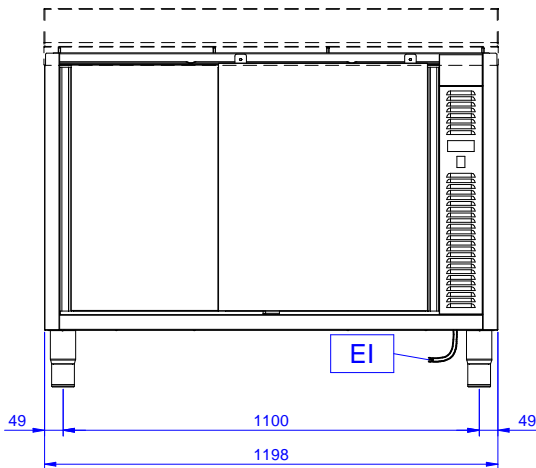

Side

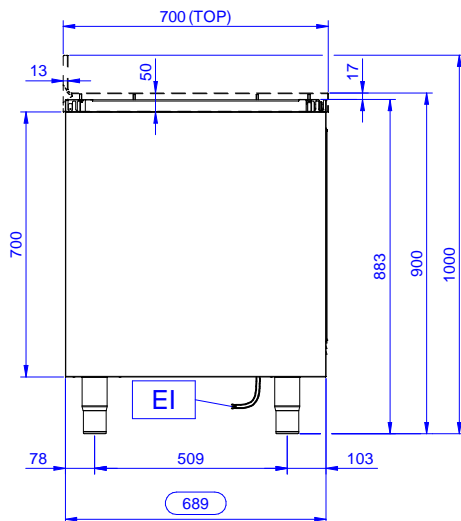

EI = Electrical inlet (power)

Top

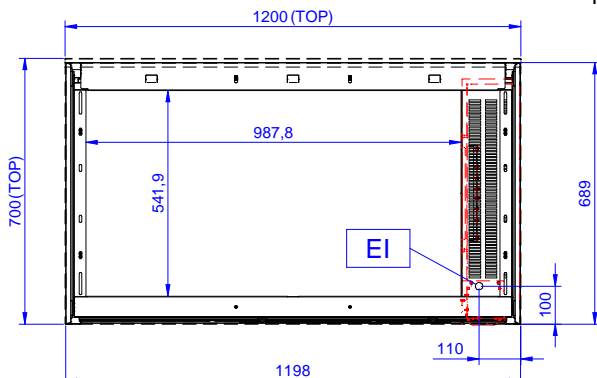

Electric

Supply voltage:

133189 (RHC1200SD)

220-240 V/1N ph/50/60 Hz

Total Watts:

2.4 kW

Key Information:

Cabinet width:	1030 mm
Cabinet depth:	645 mm
Cabinet height:	610 mm
External dimensions, Width:	1189 mm
External dimensions, Depth:	689 mm
External dimensions, Height:	883 mm
Number and type of doors:	2 Sliding
Net weight:	46 kg

 Standard Preparation
 1200 mm Ventilated Hot Cupboard with Shelf & Sliding Doors - no top

 The company reserves the right to make modifications to the products
 without prior notice. All information correct at time of printing.